

U2-S Model Combination Viewing Head and Signal Processor



WARNING

Read the instructions before use. This control shall be installed in accordance with the rules in force. Additional versions of this manual are available online at <https://customer.honeywell.com/en-US/Pages/default.aspx> in Canadian French, Portuguese, and German. Please enter 32-00015 in the search box and choose Technical Literature from the drop-down box.



AVERTISSEMENT

Lire les instructions avant l'utilisation. Cette commande doit être installée conformément aux lois en vigueur. Des versions supplémentaires de ce manuel sont disponibles en ligne à <https://customer.honeywell.com/en-US/Pages/default.aspx> en français du Canada, en portugais et en allemand. Veuillez inscrire 32-00015 dans le casier de recherche et choisissez Documentation technique à partir du menu déroulant.



WARNING

Lesen Sie vor der Verwendung die Anweisung. Diese Konsole muss entsprechend den geltenden Vorschriften installiert werden. Zusätzliche Versionen dieses Handbuchs sind online unter <https://customer.honeywell.com/en-US/Pages/default.aspx> in Frankokanadisch, Portugiesisch und Deutsch verfügbar. Bitte geben Sie im Suchfeld 32-00015 ein und wählen Sie Fachliteratur im Drop-Down Menü aus



ATENÇÃO

Leia as instruções antes de usar. Esse controle tem que ser instalado de acordo com as normas vigentes. Outras versões desse manual estão disponíveis online em <https://customer.honeywell.com/en-US/Pages/default.aspx> em francês do Canadá, português e alemão. Insira 32-00015 em cada caixa e selecione Literatura Técnica na caixa suspensa.



Disposal and Recycling

Waste electrical products should not be disposed of with general waste. Please recycle where these facilities exist. Check with your local authority for recycling advice.

GENERAL INFORMATION

The Honeywell U2-101xS series model is a viewing head and signal processor in a single enclosure intended for use with a burner control system in Industrial Flame Monitoring applications. There are several options available (see Table 1 on page 2). Each model includes one, two, or all three sensors, and can be ordered with quick disconnect (non-PF Models DIV2,ZN2) or pigtail external connection method (PF Models DIV1,ZN1).

Each sensor operates independently from another, allowing adjustment of each sensor.

IMPORTANT

Flame monitoring systems are safety systems. Please read this manual carefully and completely before installation and before attempting adjustments.

Only qualified personnel familiar with Flame Safety System should carry out installation and configuration.

U2 is certified to be used in prescribed manner. Any modification or inappropriate installation or operation may result in unsafe operation and will void implied or expressed warranty.

Sensors

The UV tube detector has a peak response at 210 nm.

The IR solid state sensor has a peak response at 1400 nm.

The UV solid state sensor has a peak response at 310 nm.

Cabling Options (Sold Separately)

ASYU2S - Quick Disconnect (non-PF) models molded connector cable assembly with 50 foot of C22S cable.

Contents

| | |
|---|----|
| GENERAL INFORMATION | 1 |
| SPECIFICATIONS | 2 |
| INSTALLATION | 3 |
| OPERATION | 6 |
| U2 MENU PARAMETER SETTINGS | 7 |
| TROUBLESHOOTING | 10 |
| SAFETY MANUAL | 13 |
| Safety Function of the U2-S Model | 14 |
| Proof Test Procedure | 14 |
| Proof Test Interval | 14 |
| Product Decommissioning | 15 |



ASYU2S-100 - Quick Disconnect (non-PF) models molded connector cable assembly with 100 foot of C22S cable.

ASYU2S-200 - Quick Disconnect (non-PF) models molded connector cable assembly with 200 foot of C22S cable.

ASYU2S-300 - Quick Disconnect (non-PF) models molded connector cable assembly with 300 foot of C22S cable.

C22S - Raw shielded 12 conductor, 22g, ITC, CIC approved. Order by the foot.

Table 1. Models and Associated Features.

| Model | Quick Connector | Pipe Fit Connection | Sensor Type | | | Typical Fuels |
|------------------|-----------------|---------------------|-------------|----|------|--------------------|
| | | | UVTron | IR | UVSS | |
| U2-1010S | X | | X | X | X | All Fuels |
| U2-1010S-PF | | X | X | X | X | All Fuels |
| U2-1010S-PF-050* | | X | X | X | X | All Fuels |
| U2-1010S-PF-100 | | X | X | X | X | All Fuels |
| U2-1012S | X | | | X | | Oil and Coal |
| U2-1012S-PF | | X | | X | | Oil and Coal |
| U2-1016S | X | | X | | | Gas and Light Oils |
| U2-1016S-PF | | X | X | | | Gas and Light Oils |
| U2-1018S | X | | X | X | | All Fuels |
| U2-1018S-PF | | X | X | X | | All Fuels |

* The U2-1010S-PF-050 has a 50-ft (15m) pigtail and the U2-1010S-PF-100 has a 100-ft (30m) pigtail.

SPECIFICATIONS

Input Power Supply: 22-26 VDC, 120 mA max (approximately 3.5 watts)

Remote Communication: 2 wire RS485 compatible with Modbus RTU protocol.

Flame And Fault Relay Contact Ratings:
1 A, 30 VDC (Resistive).

Maximum load current of 1A must be de-rated at temperatures higher than 50C ambient according to 1%/C, or 10mA/C. For example, the maximum current at 70C = 1A - (20C x 10mA) = 0.8A.

WARNING
Do not apply more than 30VDC to flame relay or self check relay.

WARNING
The U2 requires the use of an isolated 24VDC SELV (Safety Extra Low Voltage) power supply.

User Selectable Analog Output: 0-20 mA and 4-20 mA; 500 Ohm Load Max

File Select Input logic high: 21VDC min

File Select Input logic low: 16VDC max

User Interface: Capacitive TouchWheel with LED Display

Ambient temperature: -40 to 70 °C (-40 to 158 °F)

Enclosure: IP66

Weight: 2.8 kg (6.1 lbs)

Physical Dimensions: Diameter: 11.7 cm (4.6 inches)

Length: 15.5 cm (6.1 inches)

Finish: Silicone free powder coated

Mounting/Process Connection: 1" NPT female

Pipe Fit Models (PF version): 3/4" NPT

Fuses: Automatically resettable for power source and Flame Relay.

Maximum furnace back pressure: 35 Kg/Cm2 (500 PSI)

Selectable Flame Failure Response Time (FFRT):
1, 2, 3 seconds, Error= +0.0sec, -0.5sec.

Internal Temperature Indication: Degrees C or F in display menu of U2, or available at Modbus register 40019.

Self-Checking

Internal electronic self checking is performed once per second, to verify that system is operating properly. If self check detects an error, the flame relay, and self check relays will open, and the device will display "lock-out". This lockout may only be cleared by manual entry reset at the U2 Touchwheel interface.

Approvals:

Quick disconnect type
General
FM, CSA, CE (EN298), and EAC

Hazardous Location

CSA
CLASS I, DIVISION 2, GROUPS A, B, C, D
CLASS II, DIVISION 1, GROUPS E, F, G
CLASS III DIVISION 1 T5
Ex nA nC IIC T5 Gc Ex tb IIIC T85°C Db
CLASS I, ZONE 2, AEx nA nC IIC T5 Gc
ZONE 21 AEx tb IIIC T85°C Db

IECEx SIR 15.0068X Ex nA nC IIC T5 Gc
Ex tb IIIC T85°C Db IP66

SIRA 15ATEX4193X Ex nA nC IIC T5 Gc
Ex tb IIIC T85°C Dc IP66

PF version
 General
 FM, CSA, CE (EN298), and EAC

Hazardous Location
 CSA
 CLASS I, DIVISION 1, GROUPS A, B, C, D
 CLASS II, DIVISION 1, GROUPS E, F, G
 CLASS III DIVISION 1 T6
 Ex d IIC T6 Gb Ex tb IIIC T85°C Db
 CLASS I, ZONE 1, AEx d IIC T5 Gb
 ZONE 21 AEx tb IIIC T85°C Db

IECEX SIR 15.0068X Ex db IIC T6 Gb
 Ex tb IIIC T85°C Db IP66

SIRA 15ATEX1192X Ex db IIC T6 Gb
 Ex tb IIIC T85°C Db IP66



CAUTION

Possible Equipment Damage

The aluminum surface of the U2 may store an electrostatic charge and become a source of ignition in applications with a low (<30%) relative humidity. Cleaning the surface should only be done with a damp cloth.



CAUTION

Do not expose to acetone, gasoline, hexane, or ethyl acetate. label is not approved for these chemicals.

Wiring

See "Typical Installation Diagram." on page 12.

| Non-PF/Color | Function | Connection |
|--------------|--|--|
| 1-Red | Power Supply +24 VDC Connect to 22-26 VDC | To power supply positive terminal |
| 2-Purple | File Select Input, 0 or 1 | To control output. >21V input = file 1, <16V = active file defined at Modbus register 40093(default 0). |
| 3-Orange | mA output (+) | To current meter positive |
| 4-Blue | mA output (-) | To current meter negative |
| 5-Black | Power Supply Return (-) or 0 VDC | To Power Supply negative terminal. |
| 6-Yellow | Flame Relay (NO) (power in) | To flame/fault relay power source |
| 7-Green | Fault Relay (NO) (fault output) | To fault monitoring of burner control system |
| 8-Grey | Flame Relay (NO) (safety output) | To burner control system |

| Non-PF/Color | Function | Connection |
|--------------|--|---|
| 9-Tan | File Select Output, 0 or +24V output. Feedback for system controlling file input select. | To burner control system. 0V = File Select Input is low, or +24V if FileSelect Input is high. |
| 10-White | +RS485 Modbus | To Modbus + |
| 11-Drain | Cable Overall Shield | To Earth Ground |
| 12-Brown | -RS485 Modbus | To Modbus - |

*Note - pink wire unused, leave unconnected.



CAUTION

Check wiring before applying power to the system to make sure it is in accordance with the wiring chart. Incorrect wiring may result in unsafe operation or damage to U2.

NOTES:

- For remote configuration and monitoring, refer to Honeywell manuals for FlameTool for PC (32-00001-01) and HMI S7999 Panel (32-00003-01).
- A total of eight parameter files are available. Files 2 through 7 may be accessed using Flametools, and configured using Modbus register 40093.

INSTALLATION

See "Typical Installation Diagram." on page 12.

Installation should be carried out by a qualified engineer and should meet all local standards and safety requirements.

Hazardous location installations require the use of ITC/CIC approved cable installed in cable tray for non-PF models, and in metal conduit for -PF models. The cable installation must conform to the latest revision of the National Electrical Code, or Canadian Electrical Code for Class I, Division 2 (non-PF models), or for Class I, Division 1 (-PF models).



WARNING

Approved CLI, DIV1 conduit seal must be installed at PF model enclosure fitting for CLI, DIV1 hazardous location use.

Non-PF models must be secured as follows: hand-tighten the connector at viewing head until it can be turned no more. Continue tightening the connector an additional 180 degrees using pliers, or similar tool. Verify that connector cannot be loosened by hand.



WARNING

Over-tightening the connector can damage the connector or housing. Damage will void warranty and hazardous location approvals. Do not exceed 180 degrees of further rotation after hand tightening!

⚠ WARNING
EXPLOSION HAZARD
DO NOT DISCONNECT WHILE CIRCUIT IS LIVE
UNLESS AREA IS KNOWN TO BE NONHAZARDOUS.
 Substitution of components may impair suitability for class i, division 2.

The U2-S model viewing port is designed for interface to a 1" NPT (M) fitting. The viewing head can be mounted in any orientation, any angle, upward or downwards.

It is recommended that earth ground is applied at the labeled earth ground screw connection on the housing. It is recommended the drain wire be connected to earth at power supply.

To reduce noise interference from ignition transformer or other high voltage sources, make sure all high voltage cables are in good condition and are at least 300 mm (12") away from U2 wiring.

Location/Mounting on Burner

Honeywell can provide mounting accessories such as a swivel mount, heat/electrical insulator, quick mechanical disconnect, high pressure isolation unit, etc. Check with your sales representative for your application.

1. Ensure location provides clear view of the flame under all operating conditions.
2. If the burner is provided with a pipe mount, use a bell type reducer to 1" NPT (M).
3. When using purge/cooling air, make sure hoses are electrically isolated from the Earth to prevent multiple ground loops.
4. Depending upon the application, purge/cooling air pressure and flow will be different. As it is easier to measure pressure than flow, ensure that the entrance to air connection is a minimum of 25 mm WC (1" wc) above back pressure at all the time, from minimum to maximum load.
5. **IMPORTANT!**
FLAME DISCRIMINATION
 In multi-burner applications, it is important to sight for high frequency, high radiation intensity zone of the target flame, while sighting the low frequency, low radiation intensity zone of the background flame see Fig. 3 for IR, or Fig. 4 for UV for an example. This allows for filter, gain, and threshold settings to properly discriminate or recognize the target flame while rejecting background flame.
6. Where practical, use a swivel mount to allow for adjustments to optimize the flame viewing location.

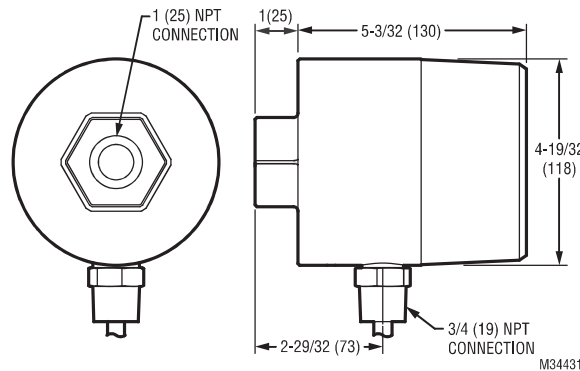

Fig. 1. Dimensional drawings.

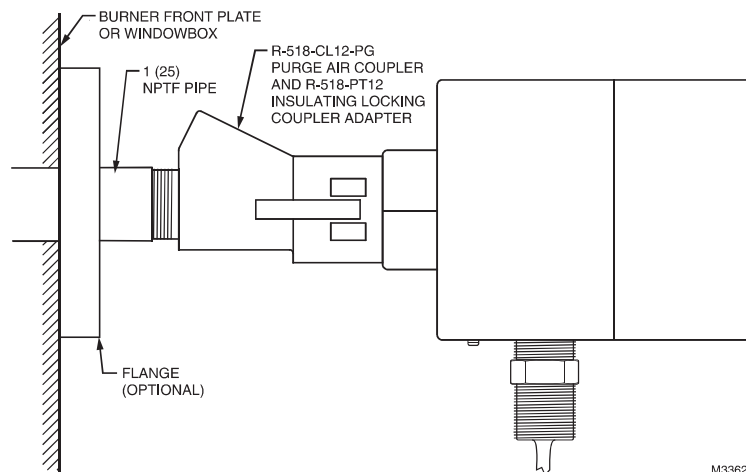

Fig. 2. Typical mounting example.

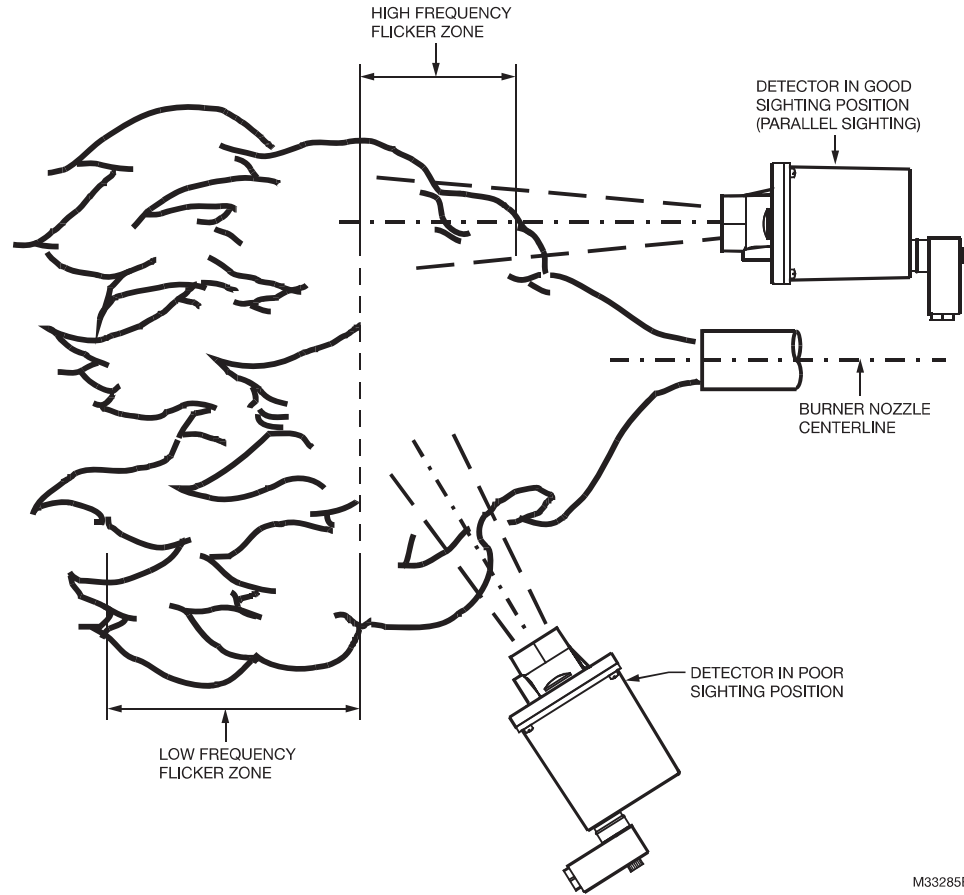

Fig. 3. IR viewing head location.

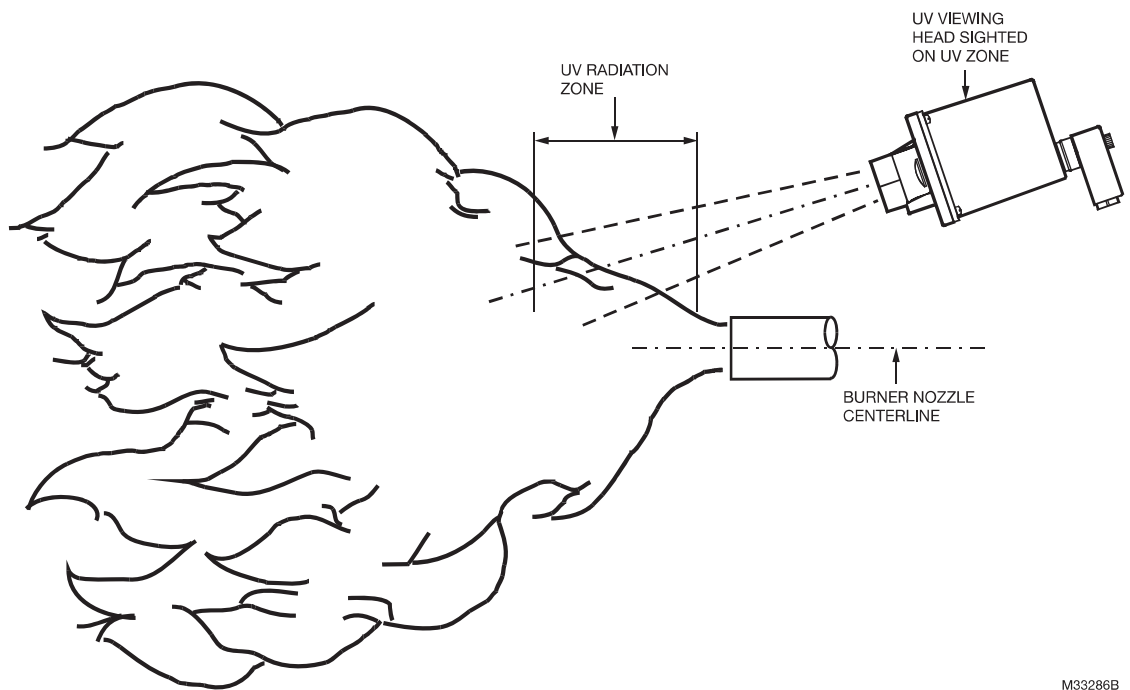

Fig. 4. UV viewing head location.

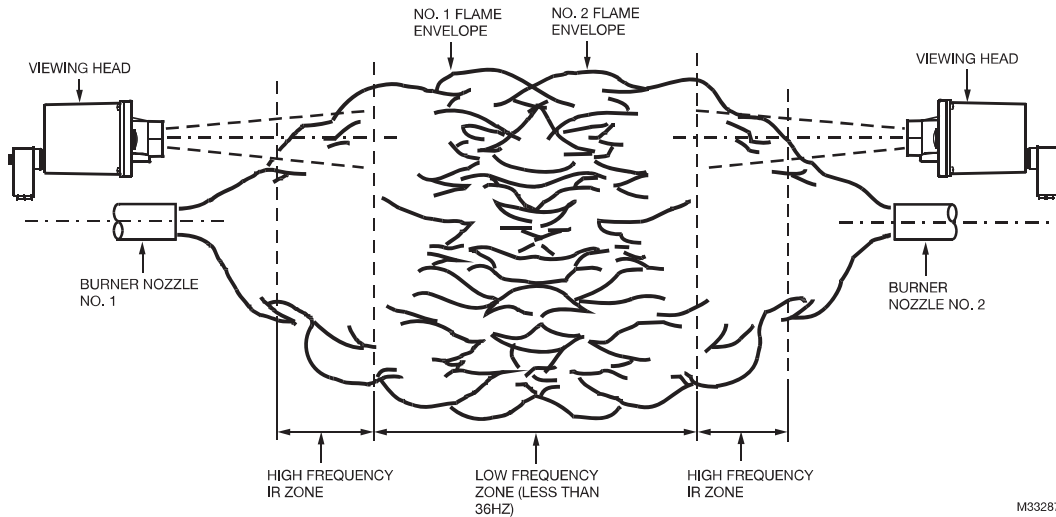

Fig. 5. Sighting opposed fired burners.

Mounting Accessories

1. Cable assemblies for quick disconnect models are listed below. All are ITC/CIC approved, and meet IP67 at connector when properly installed.
 - ASYU2S molded connector with 50 foot cable.
 - ASYU2S-100 molded connector with 100 foot cable.
 - ASYU2-200 molded connector with 200 foot cable.
 - ASYU2-300 molded connector with 300 foot cable.
2. Fiber Optic System - The U2 models are compatible with the Honeywell FASA Glass or Quartz fiber optic extension. Refer to Honeywell manual 69-2683
3. U2-S supports Modbus protocol. The system can be monitored using user's hardware and software and/or Honeywell FlameTool for PC or Honeywell FlameTool for Panel (S7999). For detail refer to manual 32-00001 and 32-00003.
4. There are several mounting accessories available from Honeywell. Please check with your sales person for detail.
 - a. R-518-PT12 (Ultem Iso PT Adapter)
 - b. R-518-PT12L (Ultem Iso PT Adapter with lens)
 - c. R-518-CL12-PG (Purge Air Coupler 1" NPTM & 1/2" NPTF)
 - d. M-701-2 (Swivel Mount)
 - e. R-518-CL12-HTG (Locking Coupler).

OPERATION

Available sensors continuously convert flame radiation to a magnitude displayed on the U2 display. The displayed value described further as "flamecount" is the sum of all active sensor readings.

If flame count is greater than the flame on setpoint for longer than the time delay, a flame on condition is realized and the flame relay contacts are closed. The flame relay contacts remain closed until the flame count falls below the flame off setpoint for longer than the flame failure response time, at which a flame off condition is realized and the flame relay contacts are opened. Periodic self

check performs fault detection, and if a fault is detected, both the flame relay and self check relay contacts are opened.

While File Input Select is low, file parameters defined at Modbus register 40093 are used to determine flame relay state. While file input select is high (+24V), file 1 parameter settings are used to determine flame relay state.

File Select Output provides feedback to indicate the state of the file input select. See chart below:

| File Input Select Value | File Select Output Value |
|-------------------------|--------------------------|
| 0V | 0V |
| 24V | 24V |

There are several parameter adjustments that permit configuration of each sensor. .

A touch wheel located at the back of the viewing head provides access to parameters for adjustment and configuration. The configuration menu is simple and easy to follow. Full character, 4-digit, scrolling LED displays are visible in the dark or sunlight. Individual sensor LEDs (model dependent 1, 2, or 3 total located below the display) flash to indicate the output of each sensor (green = UVTron, Blue = SSUV, Red = IR). The upper right green self-check LED provides indication, and status of the self check. The upper left red "Flame On" LED provides status of the flame relay.

NOTE: The number of LEDs are model dependent.

The touch wheel is designed like an iPod™ to allow for slow or fast changes by moving a finger slower or faster around the back glass. Alternatively, the user may tap ← (-) or → (+) to make changes. Swirl finger at touchwheel > 360 degrees and release to enter the menu. Tap ENTER/STORE to store selected data. Tap BACK to return to the previous menu. Exiting all of the menus will display the current flame count.

NOTE: Only the pertinent menu will be displayed. For example, for UVTron only sensor (U2-1016S and U2-1016S-PF), only UVTron gain will be displayed. UVSS and IR gain will not be visible.

Display, as seen by the user, is shown in **BOLD RED** in the list below as it appears in sequence.

U2 MENU PARAMETER SETTINGS



CAUTION

If the display shows "9999" while in operation, it indicates flamecount has exceeded maximum range of device. Reduce appropriate sensor gain(s) so that Flame count is about 1.5 to 3 times Flame OFF threshold settings. If unsuccessful, orificing or increased sight pipe length may be required.

Gain UVTron

GTX - Displays the current UVTRON tube sensor gain (adjustable 0-99). The default value is 32.

Gain SSUV

GUX - Displays the current solid state UV sensor gain (adjustable 0-99). The default value is 75. Adjusting the gain too high may result in lockout due to saturation of the sensor.

Flicker Filter Setting for SSUV

FUX - Displays the current solid state UV flicker filter setting (adjustable 0-9). The default value is 3.

Gain IR

GIX - Displays the current IR sensor gain (adjustable 0-99). The default value is 75. Adjusting the gain too high may result in lockout due to saturation of the sensor.

Flicker Filter Setting for IR

FIX - Displays the current IR sensor flicker filter setting (adjustable 0-9). The default value is 3.

Flicker settings indicated below apply to SSUV and IR. These are high pass filter setting:

| Setting | HZ | Setting | HZ | Setting | HZ |
|---------|----|---------|-----|---------|-----|
| 0 | 9 | 4 | 52 | 8 | 215 |
| 1 | 16 | 5 | 75 | 9 | 300 |
| 2 | 24 | 6 | 100 | | |
| 3 | 33 | 7 | 155 | | |

Gain MA OUT

GMX - Displays the current multiplier for analog output (adjustable 0-99). The default value is 30, and will result in approximately 12mA analog out at 1700 flamecount, and 20mA at 3425 counts. The ma gain setting allows for scaling of the analog output value proportional to the flamecount at full load. For example, increasing the gain, increases the analog output for a given flamecount. Adjusting the MA gain does not alter gain settings of UVTron, SSUV, or IR. After completing flame setpoint configuration, adjustment to the MA gain may be used to set MA output at full system load.

Flame On Threshold Setting

Displays the current Flame On threshold settings. It is important to note that flame count must reach this threshold in order for the flame relay to energize. After the flame relay is energized, the flame count may drop below Flame ON threshold but must remain above Flame Off threshold (refer to FFRT below). Range is 51- 3425 flame count.

NOTE: The Flame ON threshold setting must be 1 digit above Flame OFF setting.

Flame OFF Threshold Setting

Displays the current Flame OFF threshold settings. Flame count must remain above Flame Off threshold setting otherwise flame relay will be de-energized after Flame Failure response time has expired. Range is 50- 3424 flame count.

NOTE: The Flame Off threshold setting must be 1 digit below Flame On setting.

Flame Failure Response Time (FFRT)

RTX - Displays the current Flame Failure response time in seconds. Flamecount must remain above Flame Off threshold setting otherwise the flame relay will be de-energized after Flame failure response time has expired. FFRT selection is 1, 2 or 3 seconds. Default setting is 1 second.

IMPORTANT

The FFRT must be set to 1 second, to meet requirements defined in European Standard EN298, unless the application standard allows for longer response time. Care must be used to ensure that the overall response time of the system is acceptable for safe operation.

Flame On Time Delay

TDX - Displays the current Flame On time delay in seconds. The flame relay will be energized after the flamecount has remained above the flame ON threshold, and the time delay has elapsed. This feature is useful in applications where flames from other sources are temporarily present in target area, such as grate fired boilers. Selection is 0,1, 2 or 3.

NOTE: The time delay also reduces Trial for Ignition by the set time. Default setting is 3 seconds.

File Selection

***FOX** - The U2 is able to store up to 8 different file (configurations) (file0 - file7). Files are used to store device settings for different fuels or applications. Parameters that are stored in each file include Flame On Setpoint, Flame Off Setpoint, Flame Failure Response Time, Time Delay, UVT Gain, SSUV Gain, IR Gain, SSUV Filter, IR Filter, mA gain, and Panel timeout.

Modifying file parameters

Press ENTER at menu location FILE, and select file number using the touchwheel. Press enter when desired file number is reached. The 4 digit display will flash

decimal points to indicate file other than 0 is being modified. Change menu parameters as desired. **IMPORTANT!** Menu selections will only affect the currently selected file.

NOTE: The U2 touch wheel interface allows access to all eight files for configuration; however, the active file cannot be changed at the U2 interface. It can only be changed at the "File Select" wired input or through Modbus communication. Only two files, "0" and "1", may be automatically activated by changing the voltage input to the "File Select" wire (purple). When the file select line is power grounded, the file selection = "0", when connected to 24 VDC File select #1 is automatically activated.

NOTE: File selection for "0" may be changed, by modifying the modbus register location 40093. Default value is 0, and may be changed to 0 through 7.

⚠ WARNING
When using file select input (purple) to control parameter selection for different fuels, control system must monitor file select output (tan) to confirm U2S is using the correct file parameters. If only one file parameter is used, set file 0 and file 1 settings to identical values, and connect file input select to ground.

Panel Lock and Time Out.

Tapping the ENTER/STORE button when PANEL appears on the menu screen will provide access to two sub-menus.

Panel Lock

The Panel Lock sub-menu enables a security feature that locks the U2 interface preventing any parameter modifications.

A factory default 4-digit access code is required to enable panel lock. This code is only available from the factory. Once enabled, the same code will be required to modify parameters from the touch-wheel interface. Any attempt to make changes will generate the message, "Panel Locked Enter Code". The display will show "Bad" upon entry of an incorrect access code. Additionally, a user may select a unique lock code through Modbus, this procedure is only available from the factory.

If the password is forgotten or lost, the user must contact the factory for assistance with unlocking the panel.

Panel Timeout

The Time Out sub-menu allows for adjustment to a secondary safety feature that locks the U2 interface preventing accidental parameter modifications. This setting may be adjusted from 0-9999 minutes. After this time expires, with no touchwheel activity, any attempt to access the menu will generate the message, "KEY DISABLED ENTER 1234", simply enter "1234" as prompted by the display. The Panel Time Out is by default 10 minutes, and is disabled with a setting of 0.

Communication

The U2-S products support 2 wire Modbus RTU communication as slave devices. Default address is 0, and must be changed prior to use. The communications submenus allow adjustment of settings. See communications sub menus, and Fig. 1 for details. Default communication settings are:

- 9600 baud
- 8 data bits
- no parity
- 1 stop bit

Note that some registers are read only.

⚠ WARNING
Do not write to registers not defined in the list below.

| Register Address | Register Description | Read Write |
|------------------|---|------------|
| 40001 | FLAMECOUNT | R |
| 40003 | FLAME ON SETPOINT(50-3425) | R/W |
| 40005 | FLAME OFF SETPOINT(51-3425) | R/W |
| 40007 | MA GAIN(0-99) | R/W |
| 40011 | IR FILTER(0-9) | R/W |
| 40012 | UVTUBE GAIN(0-99) | R/W |
| 40015 | SSUV FILTER(0-9) | R/W |
| 40016 | SSUV GAIN(0-99) | R/W |
| 40019 | TEMPERATURE | R |
| 40021 | TIMEDELAY(0-3) | R/W |
| 40022 | FFRT(1-3) | R/W |
| 40085 | BAUD(24-1152) | R/W |
| 40086 | PARITY(0-2) | R/W |
| 40087 | COMM ADDRESS(0-247) | R/W |
| 40089 | KEY TIMEOUT(0-9999) | R/W |
| 40092 | NUMFILES(1-8) | R/W |
| 40093 | ACTIVE FILE(0-7) | R/W |
| 40095 | UVTUBE FLAMECOUNT | R |
| 40096 | IR FLAMECOUNT | R |
| 40097 | SSUV FLAMECOUNT | R |
| 401x0 | FLAMEON SETPOINT x = file 0-7 | R/W |
| 401x1 | FLAMEOFF SETPOINT x = file 0-7 | R/W |
| 401x2 | FFRT x = file 0-7 | R/W |
| 401x3 | TIMEDELAY x = file 0-7 | R/W |
| 401x4 | UVTGAIN x = file 0-7 | R/W |
| 401x5 | UVSSGAIN x= file 0-7 | R/W |
| 401x6 | UVSSFILT x = file 0-7 | R/W |
| 401x7 | IRFILT x = file 0-7 | R/W |
| 401x8 | IRGAIN x = file 0-7 | R/W |
| 401x9 | MA GAIN x = file 0-7 | R/W |
| 40182 | MODBUSLOCK | R/W |
| 40000 - 40300 | Other registers unlisted in this range are special use. DO NOT WRITE. | NA |

Address

For applications with many flamescanners on single modbus loop, it is recommended to start with address 11 for burner #1, 21 for burner #2 and so on.

Baud

Speed of Modbus communications (2400, 4800, 9600, 19200). The default baud is 9600.

Parity

Select Modbus checking method (NONE, ODD, or EVEN). The default parity is NONE.

RS485

Sets Modbus registers to either READ ONLY or read and writable (WRITE OK). Default is "Read and Write".

IMPORTANT!

Modbus registers should be set to read only through the menu, or locked using modbus register 40182 after system commissioning to prevent unintended writes to critical parameters. Modbus register lock requires code from factory, contact your sales representative for details.

0-20 mA OR 4-20 mA

Sets the current output to either 0-20mA or 4-20mA. The 4-20mA output is the default setting.

Auto Gain

NOTE: Auto Gain and Auto Filter only adjust solid state UV, and IR sensors. It will not adjust UV tube gain, and is non-functional in U2-1016 or U2-1016-PF models.

This menu selection automatically sets the gain for the SSUV and IR sensors necessary to generate a total flame count of approximately 1200. Desired sensors must be turned on (gain of at least 1) before auto gain is selected.

Auto Filter

This menu selection automatically sets the optimum filter for the SSUV and IR sensors. It should only be performed after the AUTO GAIN routine.

NOTE: While using the Auto Gain and Auto Filter modes, the system will be adjusting to the firing conditions at the time of implementation. This condition should be carefully selected to ensure discrimination through complete load changes from minimum to maximum and from cold burner/boiler startup to hot burner/boiler startup.

Default

Tapping will access the file default and factory default sub menus.

File Default

Selecting file default will reset the currently selected file parameters to default values (See File Selection).

Factory Default

Selecting factory default will reset all file parameters to default values, along with additional settings of panel lock code, baud rate, communications address, file selection register, and number of active files allowed.

Temperature

This menu displays the U2 internal temperature, software version, and device hours. Tapping ENTER will bring the user into the submenu that will allow changes between displaying Celsius or Fahrenheit, display the software version, or display the number of hours the unit has been in operation.

Self Check Lockout Codes

During self check if an error is detected, the flame relay and self check relay will be de-energized, and the U2 will display the message "Lockout". The lockout error code may be viewed at this point by pressing ENTER at touchwheel. The lockout error code is displayed. Next, pressing enter resets the device and normal operation is attempted.



WARNING

Before clearing the lockout, user must ensure that system is safe for continued operation. Below are lockout code definition and recommended actions for each code.

Table 2. Lockout Codes.

| Lockout Code | Failure Cause | Action |
|-------------------------------|----------------------|---|
| 1 | SSUV SENSOR | SSUV sensor failure. Adjust gain or apply orifice to lower flamecount. If failure persists, replace device. |
| 0, 2, 3, 4, 9, 10, 11, 12, 15 | INTERNAL ERROR | Clear Lockout. Verify all parameter settings, all sensor operation, correct relay operation, and overall device operation before continuing. If error persists device must be replaced. |
| 4, 7 | MEMORY ERROR | Clear Lockout. Parameter settings may be defaulted or corrupted. Verify all parameter settings and device operation before continuing. If error persists device must be replaced. |
| 5 | UV TUBE SENSOR | UVtube sensor failure. Device must be replaced. |
| 6 | UVTUBE SENSOR SUPPLY | UVTube sensor supply failure. Device must be replaced. |
| 8 | IR SENSOR | IR Sensor failure. Adjust gain or apply orifice to lower flamecount. If failure persists, replace device. |
| 14 | RELAY DRIVE FAILURE | Relay drive failure, device must be replaced. |
| 16 | POWER FAILURE | Clear Lockout. Verify power source is correctly set before continuing (24V @120ma). If error persists device must be replaced. |

TROUBLESHOOTING

| Symptoms | Remedies |
|--|--|
| No Display | <ol style="list-style-type: none"> 1. Check 24 VDC power connections and level at red and black wires. 2. Turn off power completely for 10-20 seconds to allow for internal thermal fuse to reset. 3. Check ambient temperature is below 70C (158F) |
| Display ON but flame relay contact not closing when flame recognized | Check wiring as follows: <ol style="list-style-type: none"> 1. Continuity between common (green) wire and yellow (this should be closed when power is applied -Self Check Relay) 2. If 1 above shows continuity, repeat test with green and grey wire (Flame relay). Make sure flame LED shows Flame relay is energized. |
| Lack of communication on Modbus | A unique address must be used for each loop. Address "0" disables communication. Check communication settings in menu. If using a converter, make sure the dip switches are set correctly. For further troubleshooting, check vendor information for the converter used. |

Important Information

1. When connected to an approved Burner control System, additional EMC tests are not required.
2. All external connection should not exceed 30 VDC. If higher voltage operation is required, approved interposing relay should be used.
3. The U2 must be powered using a isolated 24VDC SELV (Safety Extra Low Voltage) power supply.

Maintenance

There are no user replaceable parts in U2.

Depending upon the application, periodic cleaning of the lens may be necessary. Usually, the pressurized front of the lens prevents dirt and debris from depositing on the lens. Make sure positive pressure is maintained under all firing conditions.

User Interface

Interface Techniques:

TAP: Press a finger on a button and remove.

SCROLL: Press a finger on the glass and move the finger in circles (twirl).

RAMP: Hold a finger on the + or - button.

Two button interface (BACK and ENTER). Everything else can be done by scrolling.

Interface Modes:

FLAME DISPLAY: Tap BACK (may require more than on tap).

HELP: Tap + or - (from display).

LAST MENU: Tap ENTER, move through menu with taps or scrolls.

ADJUST MODE: Tap ENTER from adjustable menu item, change value using any technique.

NO YES MODE: Change to YES and tap STORE.

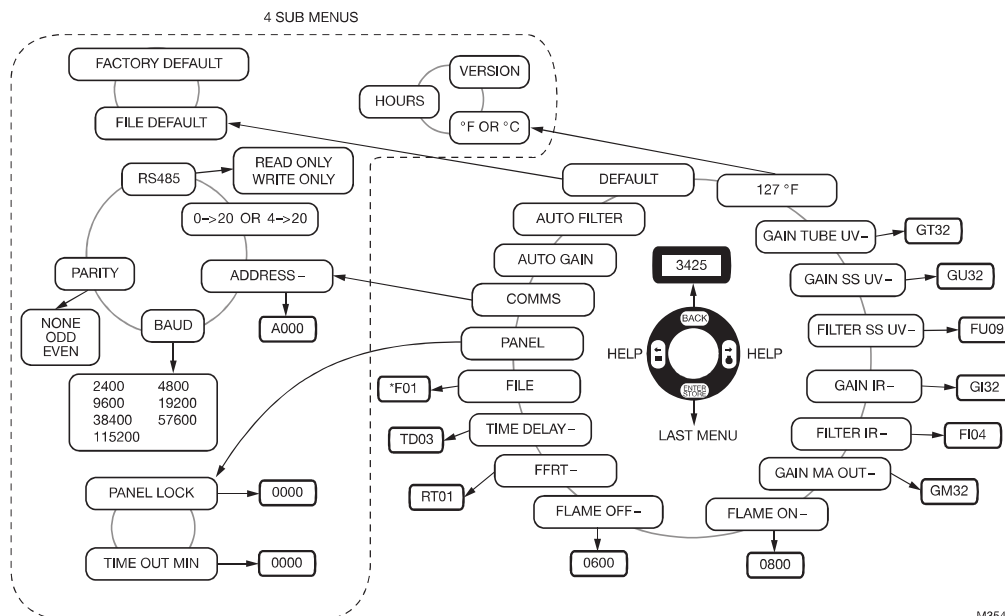

Fig. 6. User interface menu overview.

NOTE: If a sensor is not available in your model, then no menu item will exist for sensor setting. See Table 1, "Models and Associated Features,," on page 2 to determine which sensors are active in your U2 model.

U2-S Flame Threshold Setup

Desired target burner flamecount during normal operation is 1200 to 2000 counts.

Using multiple sensors is useful for monitoring different fuels, pilot/main flame monitoring, or for a high level of discrimination. See feature chart on page 2 for application sensors.



WARNING

Positioning of flame scanner, along with gain and filter settings must result in a background radiation flamecount that is less than the flame off setpoint! (Example: If target flame is extinguished, but background flame(s) are still present, flamecount must fall below flame off setpoint).

Recommended Ideal Flame On and Flame Off threshold settings:

1. Adjust available sensor filters to 0, and gain of each sensor so that flamecount under normal operation is approximately 1500 to 2000 counts total when viewing target flame under normal firing rate.
2. Take a reading of the Flame On and Flame OFF flamecount values at minimum firing rate and Maximum firing rate:
 - f. Target burner Flame ON flame count at lowest firing rate = AL
 - g. Target burner Flame Off, flame count at lowest firing rate = BL
 - h. Target burner Flame ON flame count at highest firing rate = AH
 - i. Target burner Flame Off, flame count at highest firing rate = BH
 - j. Select AL if $AL < AH$, otherwise use AH value. Let us call this value = X

k. Select BH if $BH < BL$ otherwise use BL value. Let us all call this value =Y

3. Use X, Y, along with formulas below to arrive at new Flame ON, and Flame OFF thresholds.
 - Flame ON set point = $0.75X + 0.25Y$
 - Flame OFF set point = $0.25X + 0.75Y$
4. Using new values for Flame On and Flame Off threshold, calculate FLAME ON/Flame OFF ratio. The ratio of 1.5 or higher is desirable. Adjust flame ON and flame OFF thresholds to calculated values in step 3.
5. Extinguish target flame while maximum background radiation is present. Observe flamecount, and increase filter setting(s) of sensor(s) to decrease total flamecount present from background radiation. The resulting background radiation flamecount should be adjusted to minimum. Verify that resulting flamecount falls below the flame off setpoint. If not, continue adjusting gain and filter settings, or adjust target flame sighting.



WARNING

After setup is complete, installer must test for background flame radiation below flame off setpoint when target flame is extinguished over all conditions. Failure to verify this may result in unsafe operation.

6. When filtering settings are complete, operate system once again with all flames present over minimum and maximum load, and verify proper flame threshold operation. If no further adjustment is necessary, threshold setup is complete. If gain or filter adjustments are necessary, repeat step 5 to confirm background radiation below flame OFF setpoint as any adjustments will affect both the target and background radiations.

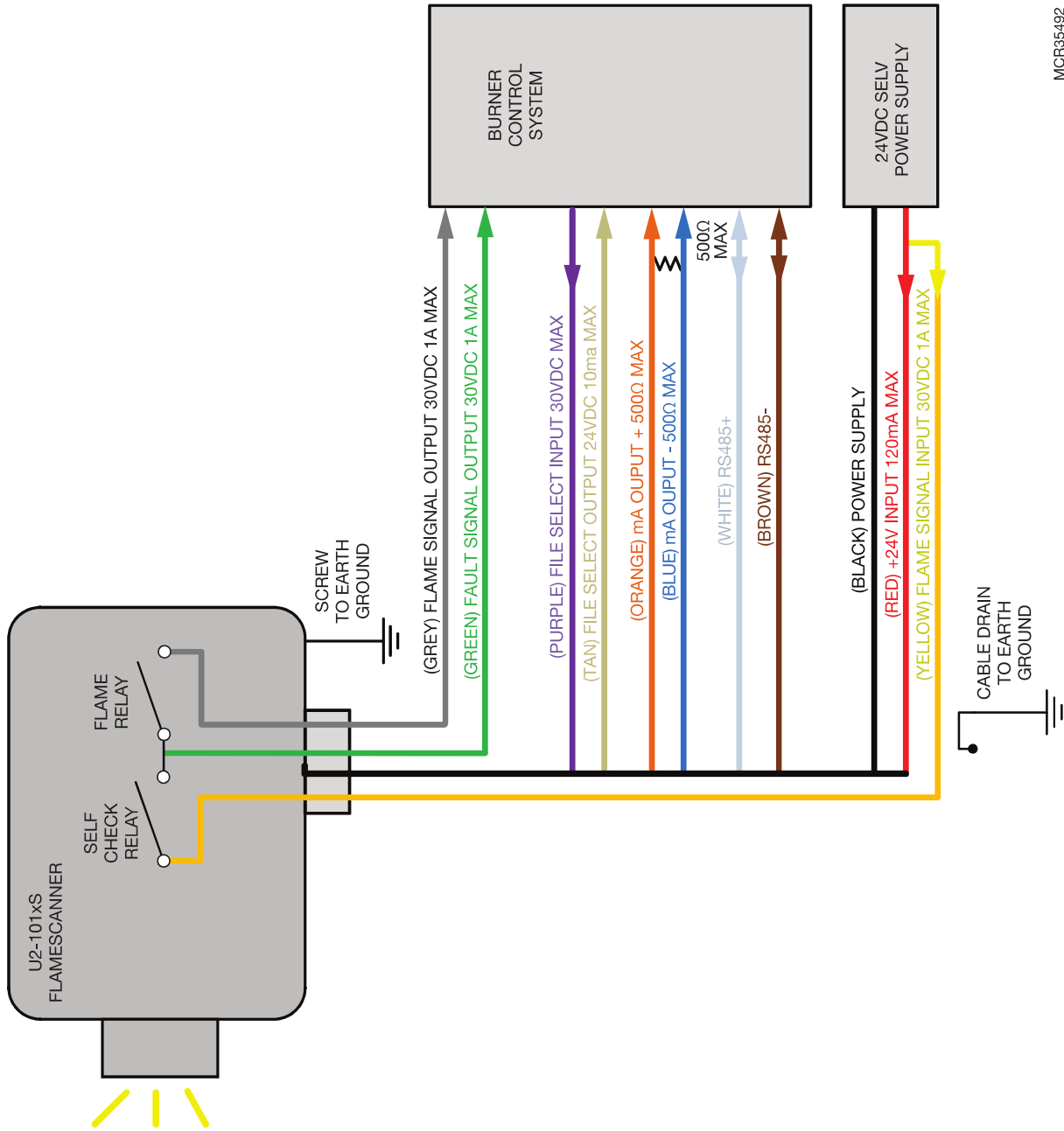

MCR35492

Fig. 7. Typical Installation Diagram.

SAFETY MANUAL

U2-S Model Product Declaration

FIT FOR USE IN A LOW DEMAND SAFETY APPLICATION

Models: U2-1010S, U2-1012S, U2-1016S, U2-1018S, U2-1010S-PF, U2-1012S-PF, U2-1016S-PF, U2-1018S-PF

| Models | SIL | HFT | SFF | PFD | λ_s | λ_{DD} | λ_{DU} |
|----------------------|-----|-----|------|-----------------------|-----------------------|-----------------------|-----------------------|
| U2-1010S/U2-1010S-PF | 3 | 0 | >99% | 1.20×10^{-4} | 1.23×10^{-5} | 3.34×10^{-7} | 5.38×10^{-9} |
| U2-1012S/U2-1012S-PF | 3 | 0 | >99% | 1.16×10^{-4} | 1.64×10^{-6} | 1.77×10^{-9} | 5.32×10^{-9} |
| U2-1016S/U2-1016S-PF | 3 | 0 | >99% | 1.15×10^{-4} | 1.06×10^{-5} | 1.74×10^{-9} | 5.27×10^{-9} |
| U2-1018S/U2-1018S-PF | 3 | 0 | >99% | 1.16×10^{-4} | 1.16×10^{-5} | 1.77×10^{-9} | 5.32×10^{-9} |

| | |
|---------------------|-------------------|
| System Architecture | 1oo1 |
| MTTR | 8 hours |
| Proof Test Interval | 5 years |
| Fit for use in | SIL 3 environment |

Definitions

| Term | Definition |
|---|--|
| Dangerous Failure | Failure which has the potential to put the safety-related system in a hazardous state |
| Safety-Related System | A system that implements the required safety functions required to achieve or maintain a safe state and is intended to achieve on its own or with other systems the necessary safety integrity for the required safety functions. |
| Safety Function | Defined function, which is performed by a safety-related system with the aim of achieving or maintaining a safe state for the plant, in respect of a specified hazardous event. |
| Proof Test | Periodic test performed to detect failures in a safety-related system so that, if necessary, the system can be restored to an "as new" condition or as close as practical to this condition. |
| MTTR (Mean Time To Restoration) | The average duration required for restoration of operations after a failure. |
| λ_{sd} | Rate of safe detectable failures per one billion hours. For example, if $\lambda_{sd} = 3000$, then it is estimated that there will be about 3000 safe detectable failures during every one billion hours of operation. For $\lambda_{sd} = 3000$, this is about one safe detectable failure every 38 years. |
| λ_{su} | Rate of safe undetectable failures per one billion hours. |
| λ_{dd} | Rate of dangerous detectable failures per one billion hours. |
| λ_{du} | Rate of dangerous undetectable failures per one billion hours. |
| HFT | Hardware Fault Tolerance |
| System Architecture | Specific configuration of hardware and software elements in a system. |
| PFD _{AVG} (Average Probability of Failure on Demand) | Average Probability of Failure on Demand. |
| FIT (Failures in Time) | A unit of measurement representing one failure per billion hours. 1,000,000,000 hours is approximately 114,155.25 years. |

Safety Function of the U2-S Model

The safety function of the U2-S signal processor consists of a Flame Relay which comprises its safety function and behaves as follows:

The Flame Relay (Normally Open)

- The Flame Relay will be energized when the product is powered and a flame on condition is detected for longer than the time delay value.
- The Flame Relay will be de-energized when the product is powered, a flame off condition is detected, and the FFRT (Flame Failure Response Time) has elapsed.
- The Flame Relay will be de-energized when the product is powered and detects a fault condition.
- The Flame Relay will be de-energized when power to the product is off.

All U2-S signal processor models contain a Self Check Relay designed to be energized during normal operation and de-energized during power off, or detection of a fault.

Proof Test Interval

The Proof test must be conducted every 1 to 5 years. This range is given to allow for the test to be performed during the normally scheduled burner shutdown period. It is the responsibility of the user to perform the proof test in the specified time frame.

The following chart for the U2-1010S shown for example, presents the dependence of the PFD_{AVG} on the proof test interval. The PFD_{AVG} increases as the proof test interval increases.

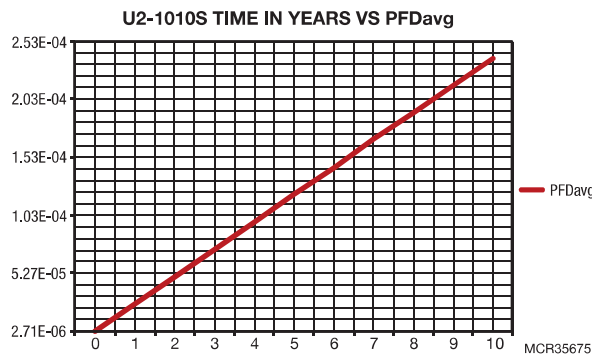

Fig. 8. 1010S PFD_{AVG} over time.

Proof Test Procedure

EQUIPMENT REQUIRED

- Powered Uniscan 2S signal processor
- Multimeter capable of voltage measurements < 50V, and resistance measurements 1 Ohm to 1M Ohm. Fluke 87 or similar.
- 24V DC Power supply < 500mA
- Light source* capable of generating a flame on condition for all sensors.

* Use an incandescent bulb for IR sensor, deep UV light for solid state UV and UV tube sensors. If none of these are available a flame may be used. Note that IR, and SSUV sensors require flickering light source.

Setup

1. Set power supply to OFF. Connect U2-S model to power supply as described in manual.
2. While performing the proof test, disconnect or disregard the signal processor so that any outputs due to testing do not affect the overall safety system and potentially cause a hazardous situation.
3. Record all previously entered user programmable settings so that they may be restored after the proof test.

Tests

1. Ensure that power is completely removed from the U2-S. Measure resistance between yellow and green wires and verify that self check relay contact is open circuit (>1M Ohm). Measure between green and gray, and verify flame relay contact is open circuit (> 1M Ohm).
2. Reapply power to the signal processor and, using a multimeter, ensure closure of the self check relay by measuring continuity* between the yellow and green wires.
* Less than ~5ohm / 50foot cable
3. Use a light source to generate a flame on condition and, using a multimeter, ensure closure of the flame relay by measuring continuity between the green and gray wires.
4. Remove any light source to generate a flame off condition and, using a multimeter measure resistance between green and gray wires, and verify flame relay contacts are open (> 1M Ohm), after the FFRT (Flame Failure Response Time) has elapsed.
5. Measure the current draw of the U2 and ensure it is less than 120 mA.
6. Change FFRT settings of the signal processor and store the changed setting. Remove power to the signal processor for 10 seconds. Restore power to the signal processor and ensure the stored value has remained unchanged.

7. Use your light source to generate flamecounts of between 1200 and 2000 in the signal processor. Note the flamecount.
 - a. Increase the gain and store the setting. Confirm the flamecount increased.
 - b. Decrease the gain and store the setting. Confirm the flamecount decreased.

8. Restore all original settings as recorded in setup and reconnect the signal processor to the safety system.

Product Decommissioning

When required, decommissioning of the U2-S flamescanner should be performed in accordance with requirements of the overall safety system.

Automation and Control Solutions

Honeywell International Inc.
1985 Douglas Drive North
Golden Valley, MN 55422-3992
www.honeywell.com

United States

Maxon, A Honeywell Company
201 East 18th Street
P.O. Box 2068
Muncie, IN 47307-0068
Tel: 765.284.3304
Fax: 765.286.8394

Europe

Maxon International bvba
Luchthavenlaan 16
1800 Vilvoorde
Belgium

Honeywell